



Promis-Electro-Optics B.V.

1/00

King of the road



PIARC International Experiment to Compare and Harmonise Skid Resistance and Texture Measurement, the Netherlands 1998.

All over the world there is more and more awareness of the importance of the quality of the road. The road network is put under severe pressure by the increasing traffic which is a major factor in road surface wear as is the effect of climate on the roads.

Roughness, cracking and rut depths are characteristics that are decisive factors in road safety and increasing road maintenance costs while also increasing costs for the motorist. Important also is the quality of the paving texture as it has a direct impact on the friction characteristics of the highway and is a primary determinant of the level of road noise generated by traffic. The Swedish company LMI Selcom developed, together with Dr Ulf Sandberg at the Swedish Road and Transport Research Institute, the first non-contact measurement system (Optocator) for surveying road conditions. Today LMI Selcom has two different families of sensors, the Optocator and SLS 5000/6000 which are available in several different versions to cover most measurement needs. All are non-contact laser probes based on the principle of triangulation.

Due to the high demands for sensitivity, precision and speed the Optocator and the SLS 5000/6000 are designed around the SiTek PSD. From 2 to 25 Optocator/SLS units can be mounted on one vehicle which makes it possible to measure the true condition

of the road. Normal measurement speed is 90 km/h and each sensor can make from 16,000 to 78,000 measurements a second depending on sensor type.

With modern data acquisition systems and computers it is possible to process and store large amounts of data. Further increasing and analysing the data will determine maintenance and repair priorities, to ascertain the efficiency of maintenance policy and to input to network evolution. This is also an important source of information when constructing new roads. The efficiency of profiling the road network has increased greatly through non-contact sensors and today more than 2,000 LMI Selcom laser sensors are used to survey the condition of roads in all parts of the world.

Important international experiment PIARC

The objective of the PIARC experiment was to investigate how differences of approach - and of technology - reflect the measurements made with the different equipment included in the experiment. These issues are of fundamental importance when executing maintenance strategy and also valuable in planning the use of network maintenance resources. Virtually all measuring principles used for mobile measurements were utilised in the experiment. It was performed at 3 locations: the USA, Japan and Europe. In the European experiment 30 devices from different countries all over the world were tested. Of these, 200 non-contact laser probes from LMI Selcom were based on SiTek PSDs. The result of this experiment will give road administrations worldwide access to a primary tool to select the device which meets their specific requirements for monitoring the road network. The final report will be presented in May 2000 in France.

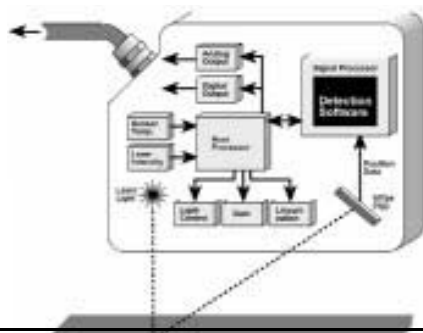

Visiting the 'Float zone'

On November 10, 1999, SiTek paid an interesting visit to our wafer supplier Topsil Semiconductor Material A/S in Denmark.

Our objective was to learn about silicon, the base material for our production. Topsil's Sales and Marketing manager as well as the Production manager welcomed us and gave us a good tour of the facilities.

Silicon is a fascinating semiconductor material. It is the second most common material on earth after oxygen. In order to produce state of the art high quality detectors SiTek uses only the purest silicon of all, the Float Zone (FZ) silicon.

Topsil is one of the world's leading supplier of this kind of silicon with more than 40 years business experience. Silicon is abundantly available in ordinary sand but as we all know sand is not a very clean material. It will take several steps of purification before this silicon is transferred into poly-silicon ingots, a form of material suitable for wafer manufacture.

For this material to be useful for electronic components, however, the crystal structure in the material has to be invariant through the whole ingot, in other words the ingot has to be one large crystal contrary to the poly-silicon which is composed of a large number independent crystals. To achieve this Topsil uses the 'Floating Zone' technique for the crystal conversion. That means that poly-silicon is melted by a high frequency induction coil. At the bottom of the melt a mono-crystalline seed crystal is introduced. This seed will work as a template for the arrangement of the crystal lattice as the molten zone is 'floated' along the entire length of the poly ingot. The end result is a



mono-crystal FZ-ingot. Adding phosphorous or boron contented gas to the molten zone controls the electrical properties of final silicon. When the single crystal has been 'pulled' it is cut into wafers. Here we had the opportunity to watch the Topsil's new wire-cutter in action. This high capacity machine uses a set of parallel wires to slice the ingot into wafers with high accuracy and similarity. Needless to say, the surfaces of the new cut wafers are very raw, and several steps of lapping, etching and polishing are needed before the wafers get the smooth, highly reflective, mirror-like surface we are used to at SiTek. Each wafer has to be absolutely free from contamination, particles and microscopic damages, so the final processing and inspection will take place in a clean room environment.

Topsil is at the front edge of FZ technology. An accomplishment that has been recorded and recognised by SiTek and that very well suits our commitment to quality. We will be looking forward to a continued close partnership with our No:1 silicon supplier.

An eye for detail

My name is Steve Swift, I'm 28 years old and moved to Sweden from England with my girlfriend in August 1999. I was very pleased to find work at SiTek and received a warm welcome from the team. After thorough training I am now working in the production of PSDs and look forward to developing my skills further. Having studied design and photography at the university I have a keen eye for detail and enjoy working with my hands. At home I can usually be found building something or other and a few years back built my own electric guitar. I am currently working on a light box for viewing transparency film since photography is another big hobby. I am very happy to be part of the SiTek team and look forward to contributing my skills to the high standard of PSD production there.



Optronic Company of the Year

We are very proud to announce that we during the year 1999 was awarded by Swedoptronics (Swedish Association of Optronic Industries) with the price, Optronic Company of the Year. The jury's motivation for the award was SiTek's progress in terms of finance as well as quality to an internationally acting company with clear ambitions to become a leading actor within its segments of the market.



Visit our new homepage at
www.sitek.se

SiTek's PSD-school

SECTION 15 by Lars Stenberg



Unsuitable mechanical design solutions

To conclude, we must investigate what happens if the optical components are installed in an inappropriate way. Figure 1 below shows how a laser diode, an achromatic lens and a main lens are mounted at the bottom of the prospective triangulation probe's housing with the aid of two holders A and B, manufactured of aluminium.

According to chapter 6 of SiTek's 'PSD school' the distance $a = 19.6$ mm and $H = 120$ mm. Let us assume that the horizontal distance between the line of the tightened screws and the system's optical axis $c = 10$ mm.

Let us now assume that the triangulation probe is to be used to measure how much an engine casing is deformed when the engine becomes hot and, let us also assume that the collimated light beam from the achromatic lens strikes the engine casing perpendicularly and that the triangulation probe's temperature increases by 30°C in the course of the trial.

Firstly, we calculate how much 10 mm aluminium is expanded when the temperature increases by 30°C and the coefficient of linear expansion for aluminium is $23 \text{ ppm}/^\circ\text{C}$. The result is $10 \cdot 30 \cdot 23 \cdot 10^{-6} \text{ mm} = 0.00696 \text{ mm}$. If, to start with, we assume that the holder B, and thereby the achromatic lens, does not move then this means that the laser diode will move to the left in Figure 1 in relation to holder B. This means that the system's new optical axis will form the angle $0.00696/19.6$ radians = 0.000355 radians with the original optical axis. This, in its turn, means that the light spot on the engine casing, M, will move to the right in the Figure 1 section $0.000355 \cdot 120 \text{ mm} = 0.043 \text{ mm}$.

Even if the distance between the triangulation probe and the engine casing is not altered during the trial the triangulation probe will nevertheless present a different distance due to the light spot being reproduced at another point on the PSD detector since the main lens registers a

change of angle as soon as the light spot moves on the engine casing M.

In order to calculate the scale of the triangulation probe's error of measurement we must calculate the distance ΔH in figure 2 below. According to chapter 3 of SiTek's PSD school the angle α is 40° and $H = 120$ mm. With the symbols of Figure 2 we obtain with the aid of uniform triangles:

$$\frac{\Delta H}{0.043} = \frac{\Delta H + 120}{120 \cdot \tan 40}$$

The calculation provides that $\Delta H = 0.051 \text{ mm}$. We thus obtain a measurement error of 0.051 mm on account of the laser diode having moved to the left in figure 2, caused by the fact that there is 10 mm of aluminium material that is exposed to linear expansion when the temperature has changed 30°C during the trial.

Please observe that we have not observed any mechanical movements or variations in the PSD detector or the triangulation probe's other electronics. If, for instance, the achromatic lens in the holder B moved as much to the right as the laser diode moved to the left the error would be doubled. If - on the other hand - the achromatic lens in the holder B were to move to the left as much as the laser diode we would obtain a much smaller error but with the opposite symbol since the laser spot would move to the left on the engine casing. Moreover, it is of interest to see how the main lens, which is placed at the distance $AE = 120 \cdot \tan 40$ mm to the right of the laser diode, is fixed in the triangulation probe's housing. Depending on how the main lens is mounted the resulting measurement error may vary between very substantial and significantly smaller measurement errors.

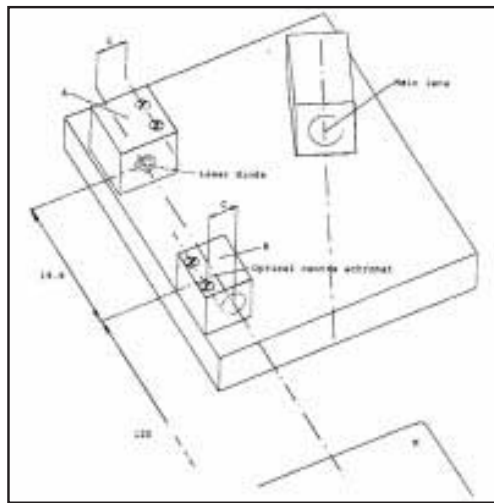

Figure 1.

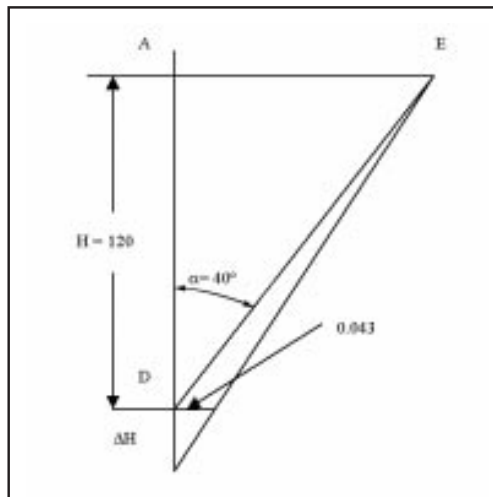

Figure 2.

When an electro-optical instrument is exposed to heat changes, it has happened more than once that those who have carried out the test have the impression that a holder moves on account of poor

fixing of the different components when - in reality - it is a question of linear expansion in the case of the materials incorporated in the instrument. For this reason an adhesive is applied between, in this case, the holder and the instrument housing. What may happen when the instrument is heated up again is that the adhesive softens at a certain temperature (for epoxy glue the temperature lies at $>40^{\circ}\text{C}$) and the holder moves somewhat resulting in errors of measurement. When the temperature decreases the adhesive hardens again and - in the worst case - the holder is fixed in a new position. This may entail that the triangulation probe presents another measurement value than that which it did formerly at the same temperature. There are, thus, reasons to think carefully before using glue in mechanical constructions.

As for myself, I normally record how an instrument measures in the course of heating or cooling under controlled test conditions in order to find out if the instrument in question measures differently at different temperatures. In this case the controlled test conditions would mean that the triangulation probe is placed in a box in which the temperature may be varied. The collimated light beams must then pass perpendicularly through a parallel plane window of good optical quality and the reflected light must likewise pass perpendicularly through a parallel plane window of good optical quality. This means, therefore, that both the windows form an angle with each other. In addition, one must carefully think through how the triangulation probe, which is to be tested, must be fixed inside the test box so that the placement in the test box does not in itself introduce errors in the distance measurement when the temperature is changed. If one removes the measured distances as a function of temperature and a bump on the curve at approx. 42°C is formed one knows then that epoxy glue is very probably at least part of the explanation for the measurement value drift when the temperature is changed.

In this case it is not a question of adding more adhesive but instead removing adhesive when the triangulation probe is mounted. Instead of gluing a component fast it may be necessary to use a screw-in mount for example.

As the reader no doubt realises, there is a great difference between constructing a measuring instrument that is to measure with almost the same precision over a large temperature range and constructing a measuring instrument for room temperatures. However, even if the constructor responsible is aware of the problem it may very well happen that the customers attempt to use a measuring instrument for a measurement application that the instrument is not designed for. For this reason customer-related problems are frequently avoided if one clearly declares within which temperature range the instrument in question is intended to be used.

Conclusion

This is the 15th and last chapter on the optical and mechanical construction of a triangulation probe. Naturally, the scope of the articles could have been extended considerably but I hope, nevertheless, that the different approaches to the problem that I have adopted may be of benefit while being of general interest for all those who work with electro-optical instruments.